

IRP208DB-4U 4U DIN Rail Box Installation

Included in this package

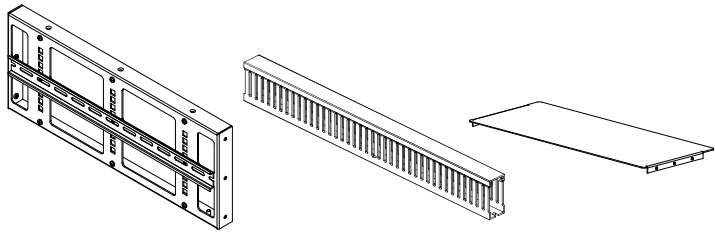

(1) 4U Main Panel (2) PVC Wire Ducts (2) Cover Panels

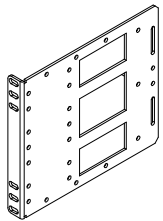

(2) 4U Ear Brackets



(24) M4 x 8 Screws

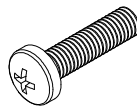

(4) #10-32 x 5/8 Rack Screws

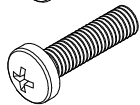

(4) #12-24 x 5/8 Rack Screws

Installation Steps

Step 1 Install Top & Bottom PVC Wire Ducts.

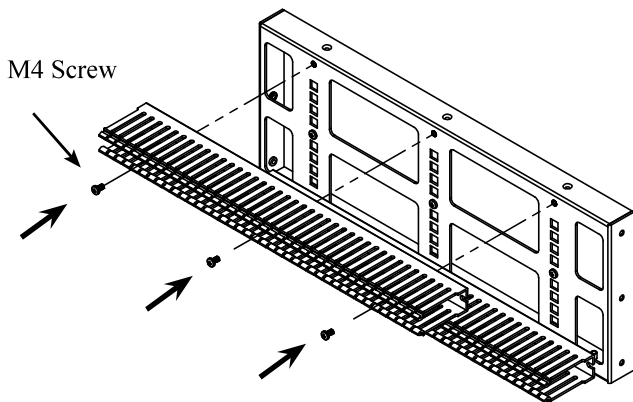

Step 2 Install Right Side Bracket. Secure side brackets with M4 screws but do not tighten them yet.

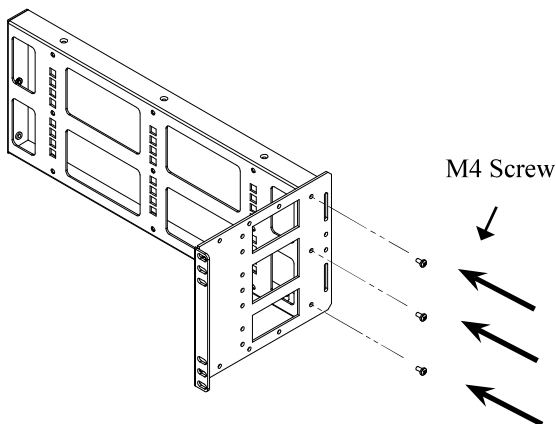

Step 3 Install Left Side Brackets. Secure side brackets with M4 screws but do not tighten them yet.

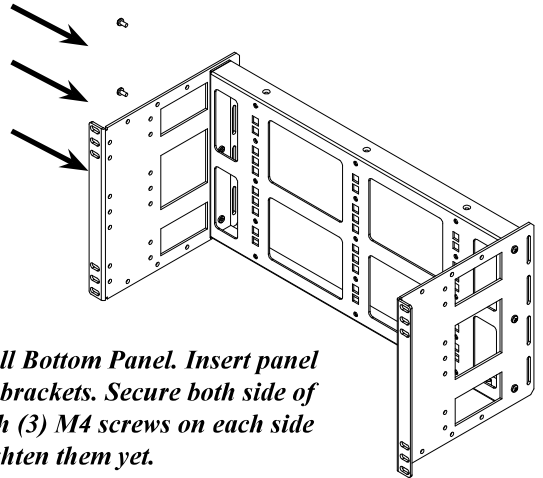

Step 4 Install Bottom Panel. Insert panel between side brackets. Secure both side of the panel with (3) M4 screws on each side but do not tighten them yet.

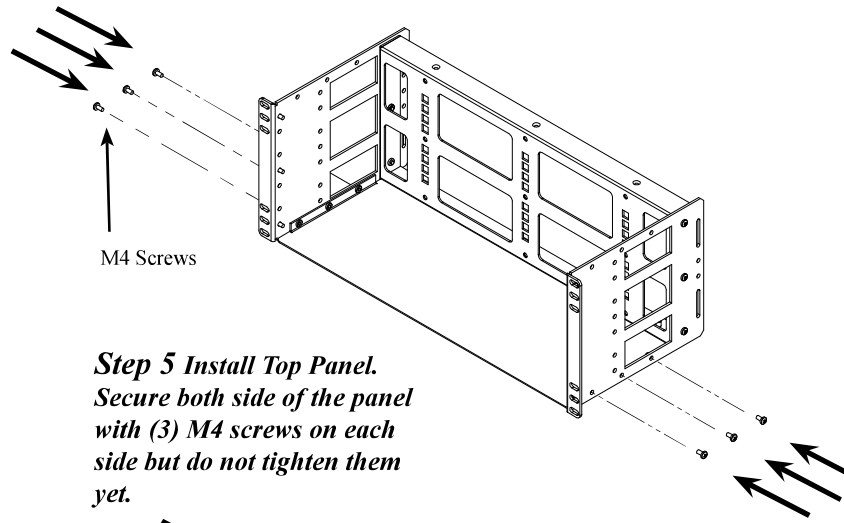

Step 5 Install Top Panel. Secure both side of the panel with (3) M4 screws on each side but do not tighten them yet.

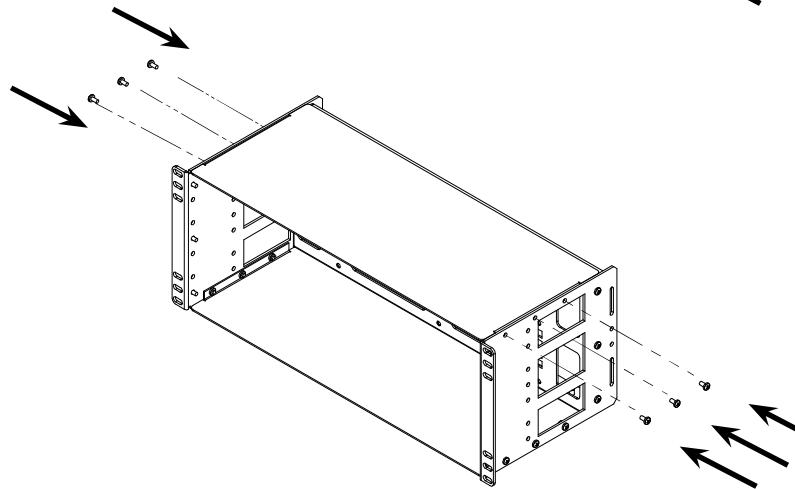

Step 6 Tighten all M4 screws on both right and left hand side. Makes sure all panels and brackets are secured and not moving. Assembly complete.